



Summary

Polaron is a Universal Serial Bus (USB) to Transistor-Transistor Logic (TTL) serial converter. The device is designed to plug into a USB type A computer jack. It provides a six-pin TTL interface for uploading programs (sketches) into Arduino¹ compatible systems - such as the many versions of Arduino Pros, Arduino Pro Minis, or Heron Circuits Proboard 328Ps and Proboard PBs, all of which use the same TTL interface. A polarized TTL cable can be used to prevent reversal of connections, and reduce risk of damaging equipment, but the TTL port of a Polaron can also connect with non-polarized 2.54 mm pitch DuPont connectors.

A Polaron is a quasiparticle, but also an Arduino compatible programming device with the following features:

- Seamless compatibility with the Arduino Integrated Development Environment (IDE)
- A genuine FT231XQ chip from Future Technology Devices International (FTDI)
- The ability to connect using either a polarized or non-polarized TTL plug
- A separate onboard 3.3 volt regulator capable of delivering up to 200 mA
- A Positive Temperature Coefficient (PTC) fuse. The fuse limits current that can be pulled from a computer's USB port to 200 mA for increased safety when powering breadboards.
- Dimensions: 44.5mm x 17.8mm (1.75in x 0.70in)
Weight: 4.0 g

Contents

| | |
|-------------------------------|---|
| 1. Top and Bottom | 2 |
| 2. Schematic..... | 3 |
| 3. Configuration | 3 |
| 4. Connecting | 4 |
| 5. Additional Resources | 5 |
| 6. Notice | 5 |

Figures

| | |
|--|---|
| Figure 1 Top View | 2 |
| Figure 2 Bottom View | 2 |
| Figure 3 Polaron Schematic | 3 |
| Figure 4 Connecting Polaron to Proboard 328P.... | 4 |

Note #1: The name “Arduino” is a trademark of the Arduino Company. “Polaron” and “Proboard” are trademarks of Heron Circuits, LLC.

1. Top and Bottom

Figure 1 shows the locations of key components.

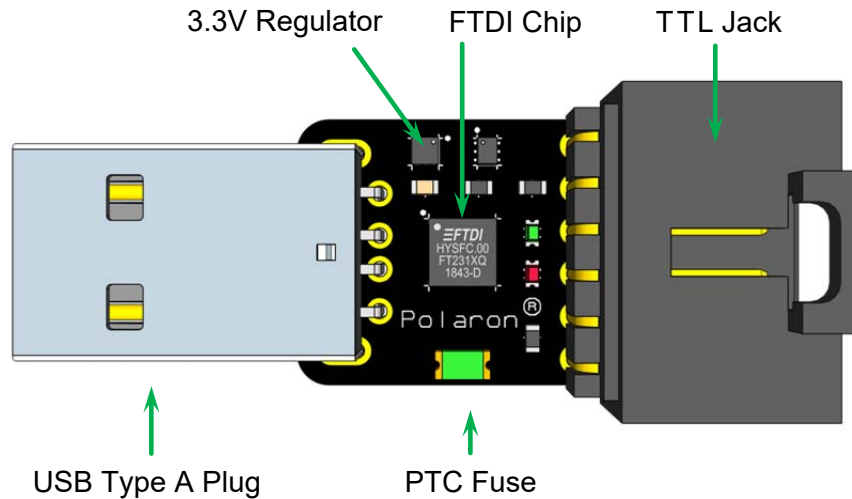

Figure 1 Top View

Figure 2 shows TTL pin names and the locations of two configuration switches SW1 and SW2.

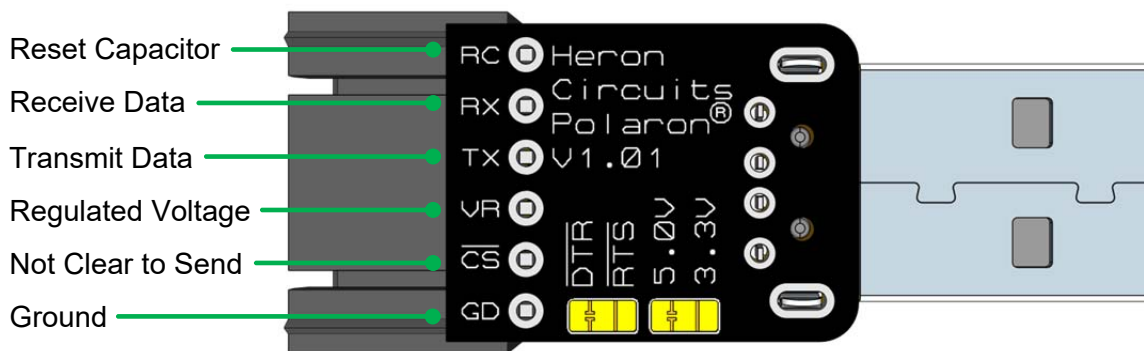

Figure 2 Bottom View

2. Schematic

As shown in the schematic in Figure 3 below, one pin in the J1 jack is RC. The RC pin connects to a reset capacitor that is embedded in all Arduino compatible systems. It supports serial TTL upload functions. Normally, the output signal on the RC pin stays high. It drops low to trigger a microcontroller reset when the Arduino IDE starts transmitting an upload. The schematic shows how a Polaron guarantees the RC output signal will snap completely low for reliable uploads. The circuit contains a pair of highly conductive MOSFET switching transistors that are cascaded to form a low impedance buffer for the reset signal.

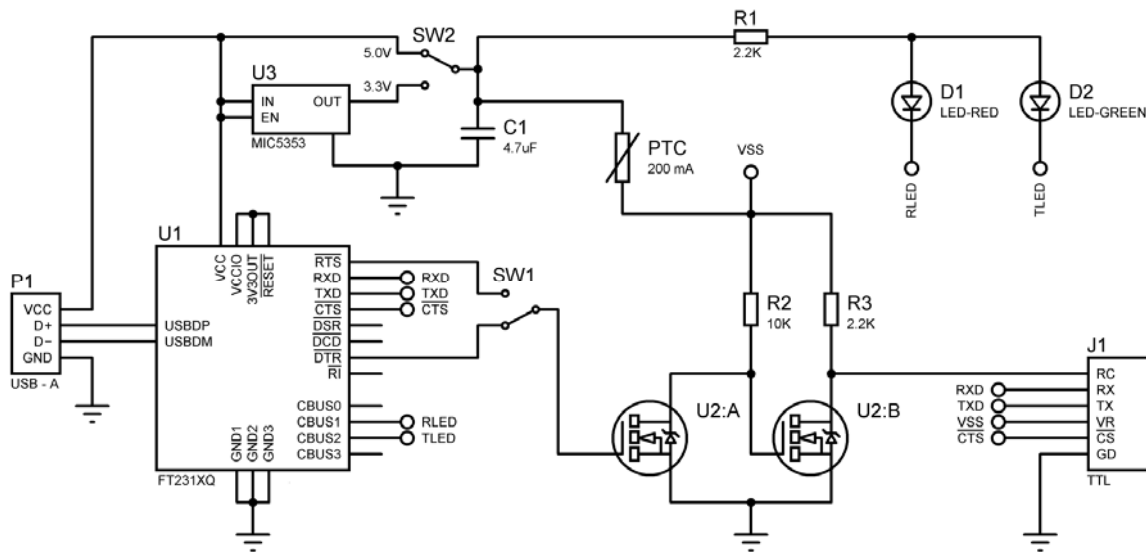

Figure 3 Polaron Schematic

3. Configuration

Polaron has two solder switches, SW1 and SW2. For SW1, the default configuration includes a thin gold trace connecting the reset logic of RC to the \overline{DTR} signal of the FTDI chip. If needed, SW1 can be changed to use \overline{RTS} instead of \overline{DTR} . This can be useful in applications such as using a Polaron to interface a computer to a serial display terminal. SW2 selects the output voltage, and is set for 5.0 volts by default.

An FT231XQ chip is capable of supplying 3.3 volts from its own built-in voltage regulator, but with very small output current. The FTDI chip's datasheet specifies 50 mA maximum, but our tests showed only about 30 mA.

The design of the Polaron includes a larger 3.3 volt regulator that can deliver 200 mA. It is included because experiments often need extra current available.

4. Connecting

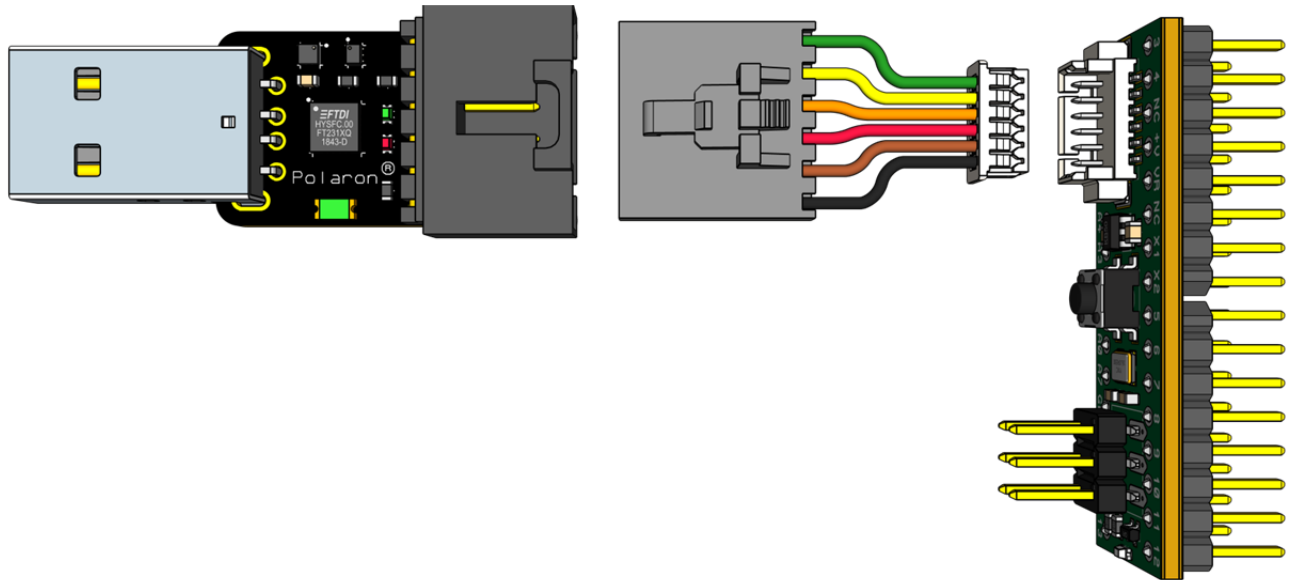

Figure 4 Connecting a Polaron to a Proboard 328P

Figure 4 shows how to connect a Polaron to a Proboard 328P. The Interconnecting Cable is pictured with wires shortened for illustration. The actual cable length is about 30 centimeters. The white plug on the right side of the cable plugs into J1 which is a wire-to-board connector with 1.25mm pin spacing.

If a Polaron is plugged into a laptop, and a Proboard 328P is plugged into a breadboard, the combination allows a user to place a laptop and a breadboard together on a table with simplified wiring. Connections at both ends of the interconnecting cable are polarized, so setups can be done without risk of accidentally orienting the TTL connections backwards. Users are free to concentrate on learning how to control components that are connected to the microcontroller on a breadboard, without worrying about the most basic connections.

A Polaron provides 200mA, which is enough current for most breadboard projects. It includes a self-resettable fuse that limits current pulled from a computer's USB port. Damage is unlikely, but when connecting any equipment to a computer the user assumes all risk. Heron Circuits will not be liable for any damage done when connecting equipment to computers, but the built-in fuse and the polarized connections both help to protect things.



5. Additional Resources

Related Products:

https://files.heroncircuits.com/documents/Proboard_328P_Datasheet.pdf

https://files.heroncircuits.com/documents/Proboard_PB_Datasheet.pdf

https://files.heroncircuits.com/documents/Proboard_21J_Datasheet.pdf

https://files.heroncircuits.com/documents/Timeport_Datasheet.pdf

6. Notice

IMPORTANT NOTICE – PLEASE READ CAREFULLY

Heron Circuits reserves the right to make changes, corrections, enhancements, modifications and improvements to Heron Circuits products and/or to this document at any time without notice. Purchasers should obtain the latest relevant information on Heron Circuits products before placing orders. Heron Circuits products are sold pursuant to Heron Circuits' terms and conditions of sale in place at the time of order acknowledgement.

Purchasers are solely responsible for the choice, selection, and use of Heron Circuits products and Heron Circuits assumes no liability for application assistance or the design of the Purchaser's products.

No license, express or implied, to any intellectual property rights is granted by Heron Circuits herein.

Resale of Heron Circuits products with provisions different from the information set forth herein shall void any warranty granted by Heron Circuits for such product.

Information in this document supersedes and replaces information previously supplied in any prior versions of this document.