

Summary

Proboard 328P systems are Arduino¹ compatible circuit boards based on the popular Microchip ATmega328P processor used in the Arduino Uno. Proboards 328Ps are narrower than Pro Minis produced by SparkFun², and other similar devices, but Proboard 328P systems provide access to a few more pins and functions of the ATmega328P microcontroller when used on breadboards.

Proboard 328Ps support timing accuracies of ± 10 parts per million. Analog and digital circuits can be powered by separate voltages, a feature that allows greater versatility when used in portable scientific instruments. A transistor buffer prevents the LED blinker from loading the Serial Peripheral Interface (SPI) clock, which can improve high speed SPI communications. Proboards plug into optional Timeport[®] accessory boards for access to lithium polymer battery charging and DC voltage conversion, as well as timed shutdown functions and connection to Sideboard™ modules.

Features of the Proboard 328P:

- ATmega328P microcontroller
- Preinstalled OPTIBOOT bootloader
- Automatic integration with the Arduino IDE, no special configuration files are needed.
- A polarized TTL connector for interfacing with a Heron Circuits Polaron[®] FTDI USB to TTL converter
- Compatibility with generic USB to TTL converters
- In Circuit Serial Programming (ICSP) port for burning of alternative bootloaders and fuses
- 22 digital I/O pins, 7 analog inputs, 6 PWM outputs
- 16MHz quartz crystal, ± 10 parts per million
- Onboard voltage regulator +5.0 volts direct current (VDC), 150mA, accepts +6VDC to 16VDC input
- 32KB flash memory - 0.5K used for bootloader
- Dimensions: 41.9mm x 12.2mm (1.65in x 0.48in)
Weight: 4.3g

Contents

| | |
|---------------------------------|----|
| 1. Pinouts | 2 |
| 2. Schematic..... | 4 |
| 3. Configuration | 5 |
| 4. Signal Descriptions..... | 6 |
| 5. Powering Proboard 328P | 6 |
| 6. Connecting | 7 |
| 7. Programming | 9 |
| 8. Typical Applications..... | 10 |
| 9. Additional Resources | 10 |
| 10. Notice | 10 |

Figures

| | |
|--|---|
| Figure 1 P1 Header Pins | 2 |
| Figure 2 TTL Connections for J1 | 3 |
| Figure 3 ICSP Connections for J2 | 3 |
| Figure 4 Proboard (Green Board) Schematic..... | 4 |
| Figure 5 Configuration Switches..... | 5 |
| Figure 6 Using a USB to TTL Converter..... | 7 |
| Figure 7 Connecting a Polaron | 8 |
| Figure 8 Downloading the Arduino IDE | 9 |

Tables

| | |
|---------------------------|---|
| Table 1 Header Pins | 6 |
|---------------------------|---|

Note #1: The name “Arduino” is a trademark of the Arduino Company. “Proboard” is a trademark of Heron Circuits, LLC. Proboard 328P systems are not made by the Arduino Company, but they are recognized as being functionally identical to Arduino Unos by the Arduino Integrated Development Environment (IDE).

Note #2: Heron Circuits, LLC is not affiliated with the Arduino Company, Adafruit, OSEPP or SparkFun, but we recommend their products.

1. Pinouts

Figures 1-3 are pinout diagrams for P1 (32 male pin header plug), J1 (TTL jack) and J2 (ICSP jack).

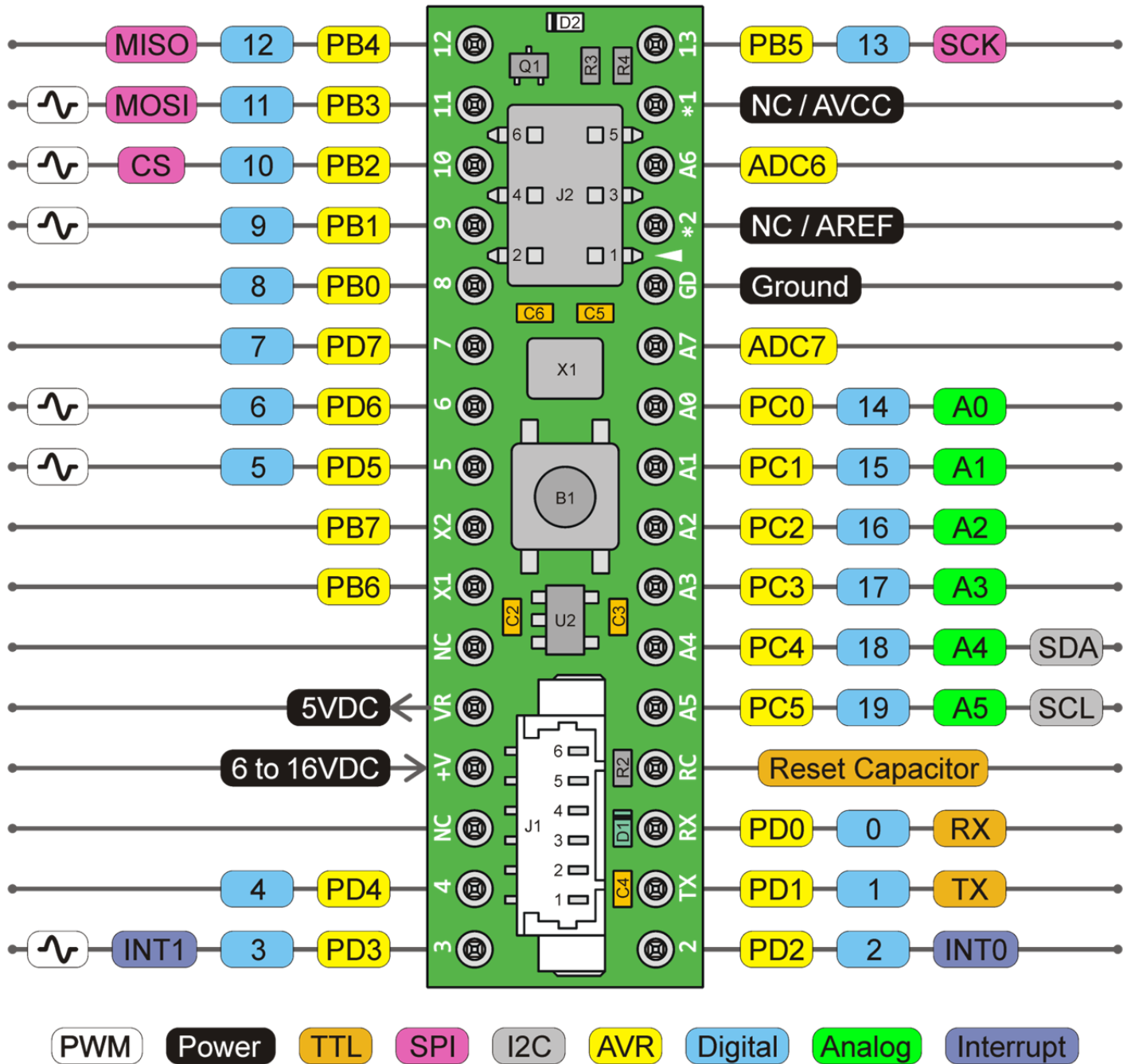

Figure 1 P1 Header Pins

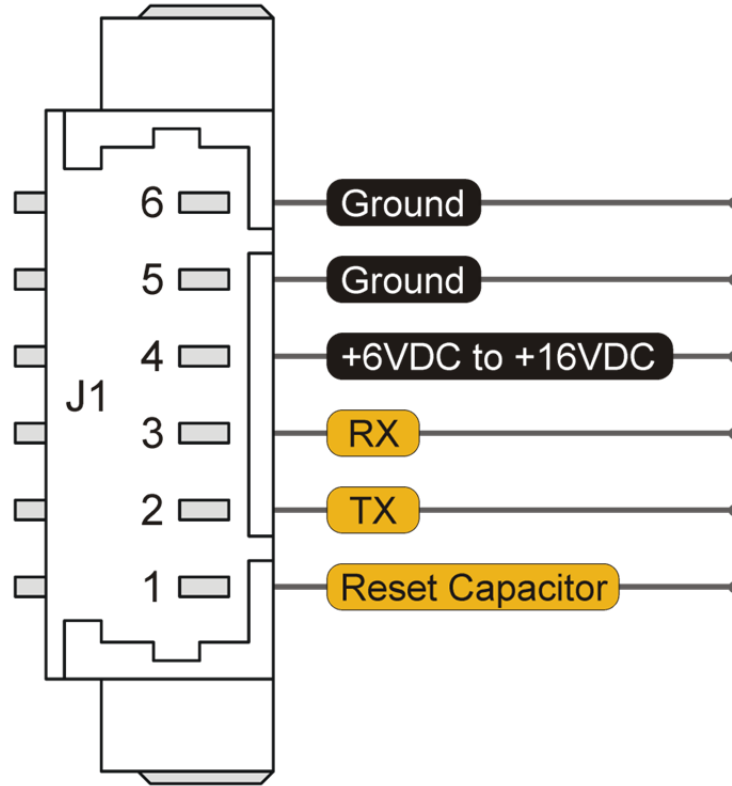

Figure 2 TTL Connections for J1

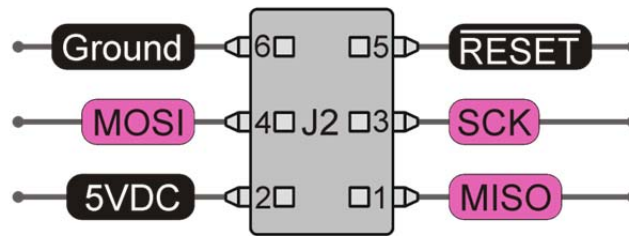

Figure 3 ICSP Connections for J2

2. Schematic

Heron Circuits Proboards exist in two colors. Green boards (Proboard 328Ps) are based on the ATmega328P microcontroller. Heron Circuits “Proboard PB” systems are blue, and are based on the ATmega328PB chip. The schematic below and all notes in this datasheet are for the green boards which are 100% compatible with standard Arduino Uno systems. If a PB chip is needed, please refer to separate Proboard PB product literature for information about the blue boards, and the ATmega328PB microcontroller.

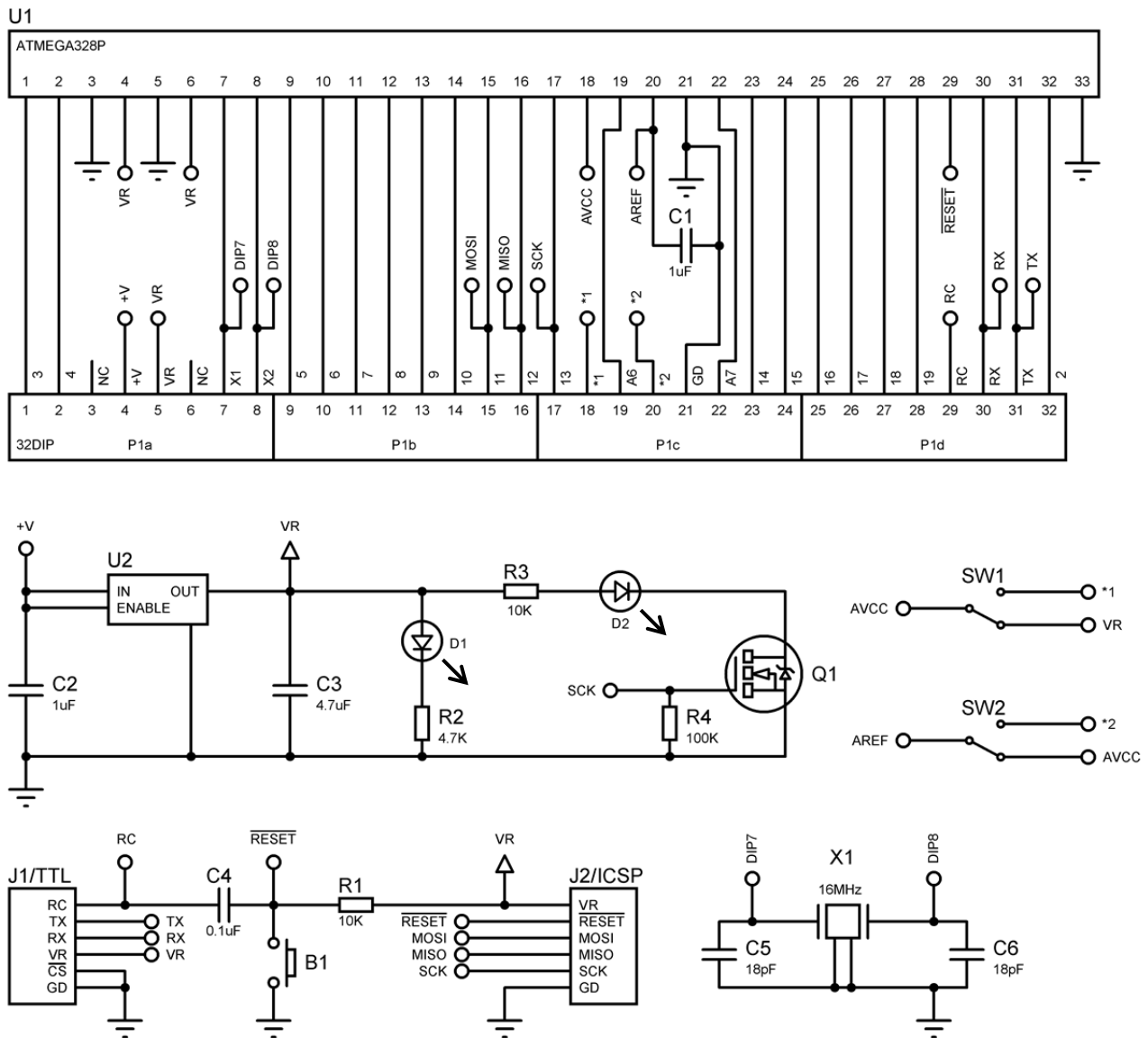

Figure 4 Proboard (Green Board) Schematic

3. Configuration

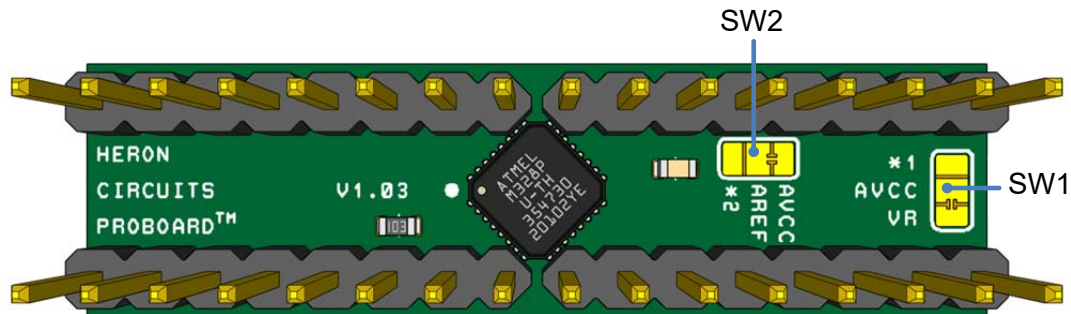

Figure 5 Configuration Switches

Proboard 328Ps have two solder switches, SW1 and SW2 as shown in Figure 5, plus two extra disconnected pins marked *1 and *2. To find the extra pins, see the P1 pinout in Figure 1.

The default switch configuration has a thin trace in SW1 connecting the processor's AVCC input to the output of the Proboard 328P's onboard voltage regulator, VR. The solder switch SW1 can be used to connect the processor's AVCC input to an alternate external voltage on pin *1. By default, SW2 connects the processor's analog reference, AREF, to whatever voltage a user has selected for AVCC by using switch SW1. SW2 can be used to disconnect AREF from AVCC, and connect AREF to the *2 pin.

As shown in the figure, by default, the AVCC and AREF connections are both wired to VR which also powers the processor's digital circuitry. This setup matches all standard Arduino compatible microcontroller boards, and for most applications there is no need to change it. The switches are provided to allow advanced users the freedom to solve absolutely any problem by using any needed processor configuration, but you should understand that making modifications involving cutting of traces will void the warranty.

Proboard 328Ps are designed to be powered by DC +6V, +9V, or +12V fed into the pin marked "+V" in Figure 1. Each Proboard is warranted to be free from manufacturing defects at the time of manufacture, but connecting the +V pin to any voltage outside the range of 0V to +16VDC or connecting any of the other pins to voltages outside the range of 0V to +5.0VDC will also void the warranty, and probably release magic smoke, so don't.

The user assumes all risk associated with cutting traces by using sharp tools, and soldering using hot tools. Using all necessary cautions, an experienced hobbyist can cut the prewired traces by using the tip of a fresh hobby knife blade. Then, add a small blob of solder to connect the center pad to the opposite setting. Put the Proboard into a circuit board vise while being careful to avoid bending pins. Use a head-mounted magnifier, and good lighting.

4. Signal Descriptions

Table 1 Header Pins

| Pin Name | Description |
|----------|---|
| RX | Receive serial data |
| TX | Transmit serial data |
| 2 to 13 | Digital Input / Output (I/O) pins |
| A0 to A5 | Combination analog or digital I/O pins, also known as digital pins 14 to 19 |
| A6 | Input to Analog to Digital Converter 6 (ADC6) |
| A7 | Input to ADC7 |
| NC | Not connected |
| +V | Input into the onboard voltage regulator, +6VDC to +16VDC |
| VR | Regulated +5.0VDC output from the onboard voltage regulator |
| X1, X2 | Crystal terminals, can also function as two extra digital I/O pins |
| *1 | Floating pin, an alternate connection for AVCC |
| *2 | Floating pin, an alternate connection for AREF |
| GD | Ground pin |
| RC | Reset Capacitor conducts RTS or DTR signal to reset the microcontroller |

5. Powering Proboard 328P

Users have multiple options for supplying power.

- Connect the positive terminal of a +6VDC to +16VDC power supply to the pin marked +V, and connect the negative terminal of the power supply to the GD connection.
- Although not recommended for full speed 16MHz operation, the ATmega328P processor can run on voltages as low as 3.0 volts and still function. For best timing accuracy, use +5.0VDC.
- A reduced input voltage below +5.0VDC can be applied directly to the VR terminal. It is always safest to supply power to the +V input terminal instead, and allow the onboard voltage regulator to protect the system.
- If a reduced voltage is applied directly to the VR terminal, the output of the onboard voltage regulator is protected by an internal blocking diode, so the reduced input voltage on VR will not feed current back into the unused onboard voltage regulator in such low power applications.
- Any standard TTL to USB converter can be used to supply +5VDC power to the Proboard 328P.
- A regulated +5.0VDC supply can be connected to pin 2 of the ICSP programming port (J2).
- Install a Proboard 328P into a Timeport accessory panel. Timeport accessory boards allow connecting jumper wires to Proboard 328P connections from either the top or bottom surfaces, and can connect to optional Sideboard modules. Timeport boards are able to smart charge lithium polymer cells, and can boost a lithium cell's voltage up to a regulated +5.0VDC at 2.0 amps for powering portable projects.

6. Connecting

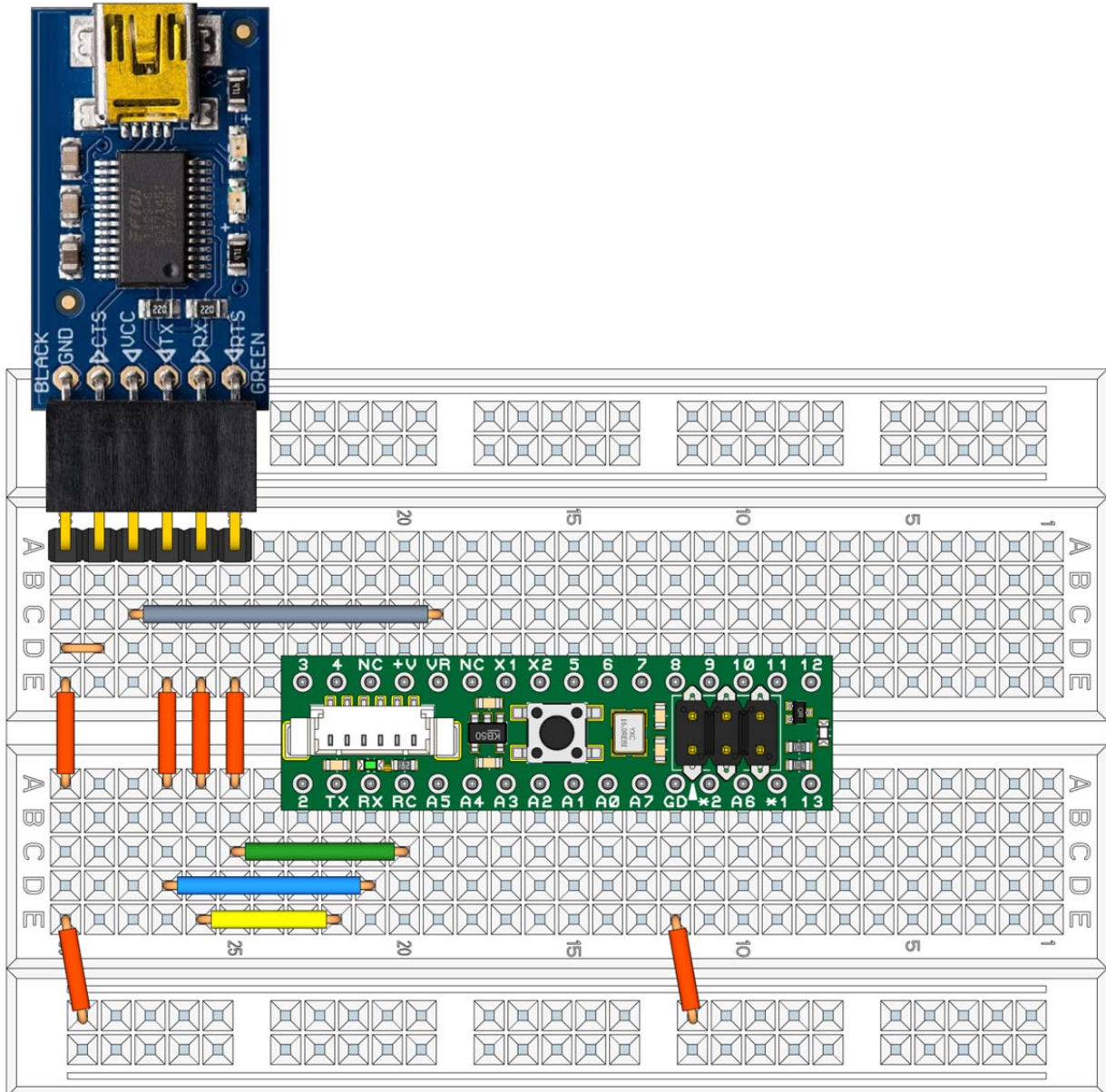

Figure 6 Using a USB to TTL Converter

Figure 6 shows how to use a generic USB to TTL converter for transferring sketches into a Proboard 328P. The six-pin device shown is produced by Adafruit, but similar devices are available from other manufacturers. Some have the pins arranged in a different order, but devices from Sparkfun and OSEPP have pinouts identical to the device shown above. We recommend using a USB to TTL converter that contains a genuine Future Technology Devices International (FTDI) chip, even though other USB to TTL chips also work

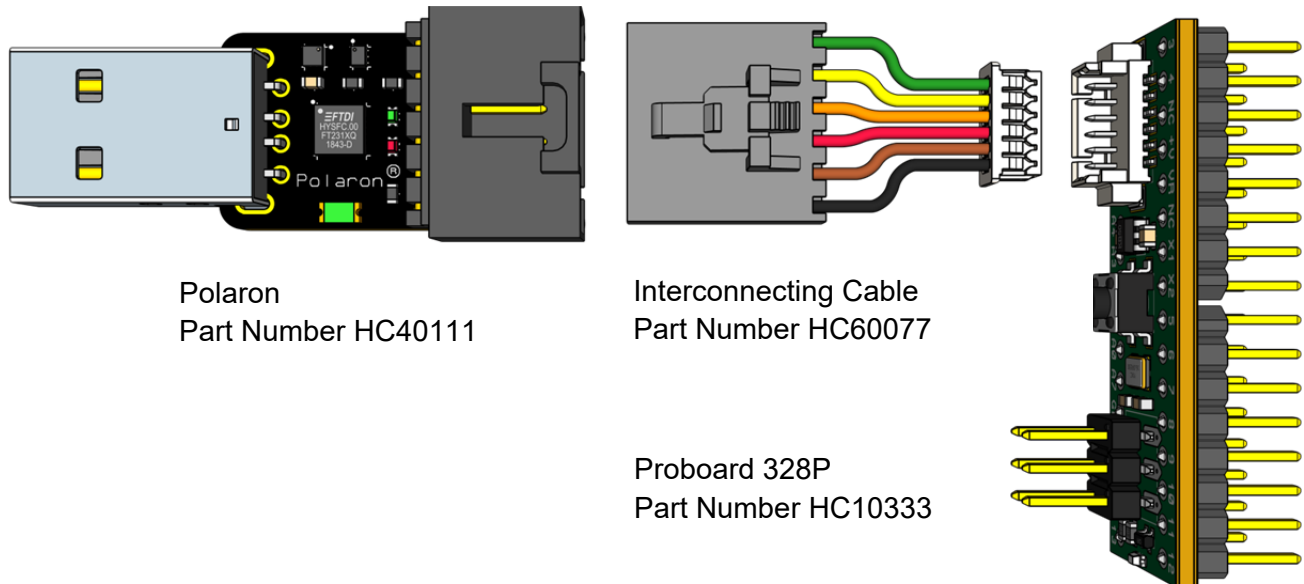

Figure 7 Connecting a Polaron

Figure 7 shows how to connect a Polaron USB to TTL converter to a Proboard 328P. The cable shown is pictured with wires shortened for illustration. The actual cable length is about 30 centimeters. The white plug on the right side of the cable fits into J1, which is a wire to board connector with 1.25mm pin spacing.

It is not necessary to use the Polaron accessory and interconnecting cable. Many users will prefer to use a more generic USB to TTL converter as shown in Figure 6, but the hookup shown above in Figure 7 has advantages.

If a Polaron is plugged into a laptop, and a Proboard 328P is plugged into a breadboard, the combination places a laptop and a breadboard together on a table with simplified wiring. The connections at both ends of the interconnecting cable are polarized, so setups can be done without accidentally plugging the TTL connections backwards. Users are free to concentrate on learning how to control equipment connected to the microcontroller on the breadboard.

A Polaron can provide 200mA, which is enough oomph for most breadboard projects. The device also includes a self-resettable fuse that limits the current that can be pulled from a computer's USB port. Damage is unlikely to happen, but when connecting any equipment to a computer the user assumes all risk. Heron Circuits will not be liable for any damage done when connecting equipment to computers, but the built-in fuse and the polarized connectors effectively reduce risk. See the Polaron data sheet for more information.

7. Programming

You can program your Proboard 328P by using the bootloader that is already installed in the Proboard 328P when it arrives. Start by navigating to <https://www.arduino.cc/en/main/software> where you can download the latest Arduino IDE to your computer. Choose the option pictured in Figure 8 if you need the Windows 10 EXE installer.

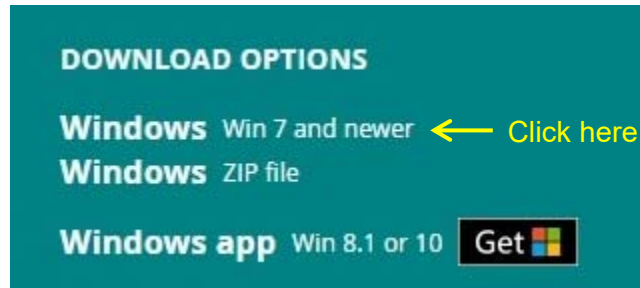

Figure 8 Downloading the Arduino IDE

The Arduino IDE will allow you to upload or write your own sketches (programs) for your Proboard. Note that for the green Proboard 328Ps, there is no need to install drivers or modify the Arduino IDE by linking JSON files. It all just works immediately.

When you are ready to upload a sketch into a Proboard 328P, select “**Arduino Uno**” from the “**Tools/Board:**” menu of the Arduino IDE. The IDE will recognize a Proboard 328P exactly as it would recognize an Arduino Uno running at the default Uno clock speed of 16 MHz.

Next, tell the IDE which serial port your USB to TTL converter has been assigned to, such as COM2, COM3, etc. On a Mac it will look like `/dev/tty.usbserial-A6006hSc`.

Finally, upload a sketch by choosing “**Upload**” from the “**Sketch**” menu. You will see the LEDs flash on the USB to TTL converter followed by a message in the IDE’s status bar: “**Done Uploading.**” Try it with the classic blink sketch at **File>Examples>01.Basics>Blink**. The blinking LED will be white, located at the end of the Proboard 328P near the “In System Programming” (ISP) connector, J2.

If anything is not hooked up right, such as a cable not plugged in, or if a serial port is not selected correctly, the upload will fail twice. For some reason unbeknownst, immediately after you correct whatever is at fault, and then try the upload again, the Arduino IDE remembers that it failed previously. It shows the error message again just to make double certain you read it. If that happens, simply do the upload a third time. The third time is the charm.



8. Typical Applications

- An educational tool for learning how to use sensors and actuators with microcontrollers
- Development of basic coding skills for programming microcontrollers.
- A controller for battery powered portable equipment.

9. Additional Resources

There are hundreds of internet sources for learning projects. Some of our favorites include:

- The Arduino Project Hub at <https://create.arduino.cc/projecthub>
- How To Mechatronics at <https://howtomechatronics.com/arduino-projects/>
- Circuit Digest at <https://circuitdigest.com/arduino-projects>
- The community at <https://www.hackster.io/arduino/projects>
- Spark Fun at <https://www.sparkfun.com/categories/103>
- Lady Ada at <https://www.ladyada.net/learn/arduino/>
- Search Amazon and YouTube for “Arduino.”

Related products:

- https://files.heroncircuits.com/documents/Proboard_PB_Datasheet.pdf
- https://files.heroncircuits.com/documents/Proboard_21J_Datasheet.pdf
- https://files.heroncircuits.com/documents/Timeport_Datasheet.pdf
- https://files.heroncircuits.com/documents/Polaron_Datasheet.pdf

10. Notice

IMPORTANT NOTICE – PLEASE READ CAREFULLY

Heron Circuits reserves the right to make changes, corrections, enhancements, modifications and improvements to Heron Circuits products and/or to this document at any time without notice. Purchasers should obtain the latest relevant information on Heron Circuits products before placing orders. Heron Circuits products are sold pursuant to Heron Circuits' terms and conditions of sale in place at the time of order acknowledgement.

Purchasers are solely responsible for the choice, selection, and use of Heron Circuits products and Heron Circuits assumes no liability for application assistance or the design of the Purchaser's products.

No license, express or implied, to any intellectual property rights is granted by Heron Circuits herein.

Resale of Heron Circuits products with provisions different from the information set forth herein shall void any warranty granted by Heron Circuits for such product.

Information in this document supersedes and replaces information previously supplied in any prior versions of this document.