

## Summary

Timeport is a power management accessory board that expands the functionality of Heron Circuits Proboard 328P or Proboard PB systems. Timeport provides lithium polymer (LiPo) battery charging, voltage boost conversion and a user controllable power shutdown feature with an independent timer.

The device includes a 32 pin connector that can be used for prototyping by connecting jumper wires, or it can be used for interfacing with Sideboards™ which contain sensors, displays, or data storage and communications equipment.

Features of the Timeport:

- 100 mA or 350 mA LiPo cell charging rate
- Boost converts 3.7 volts to provide 5.0 volts and up to 2.0 amps DC for portable projects
- A timed shutdown function can be configured using mechanical switches, or by using commands from a Proboard or a Proboard PB
- Dimensions: 63.6mm x 41.9mm (2.5 in x 1.65 in)
- Weight: 18g

## Contents

1. Interface Configuration .....	2
2. Timing Configuration .....	3
3. Charging Functions .....	4
4. Important Notes on Safety .....	4
5. Schematic.....	5
6. Commands from the Proboard .....	6
7. Additional Resources .....	7
8. Notice .....	7

## Figures

Figure 1 Timeport with Proboard 328P Installed ...	1
Figure 2 Top View .....	2
Figure 3 Bottom View .....	3
Figure 4 Schematic.....	5

## Tables

Table 1 Timeport Commands .....	6
---------------------------------	---

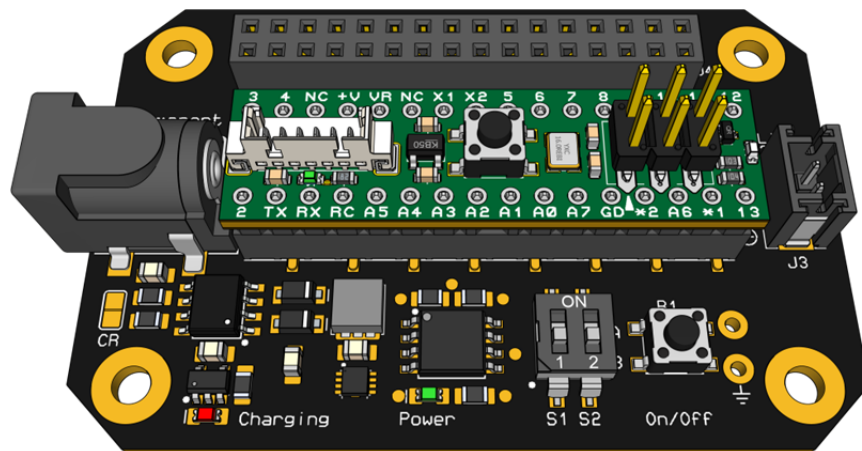

**Figure 1 Timeport with Proboard 328P Installed**

## 1. Interface Configuration

Jack J1 is a power connector located at the left edge of the printed circuit board as shown below in Figure 2. J1 accepts voltage between +6 to +16 volts direct current (DC) using the same type of power plug that fits most Arduino compatible systems. Voltage into J1 can be connected backwards accidentally without causing damage to the Timeport or the Proboard. The power plug should be a coaxial type with a 2.1 mm inside diameter, a 5.5 mm outside diameter, and a positive center.

Jack J2 is a pair of rails down the center of the board. A Proboard or a Proboard PB plugs into J2 as shown in Figure 1. Either type of Proboard can be installed into J2 backwards without harm, but the systems will only function if plugged in correctly. Use the dots inside the rails as guides. They resemble the pins on the tops of the Proboards.

Jack J3 is a 2.0 mm pitch connector for attaching a battery. Connect only a good quality 3.7 volt LiPo cell. Take special note that the polarities of the terminals of J3 are marked on the board near J3. You must use a LiPo cell with the wires connected correctly. Connecting a cell to J3 with backwards plug polarity would destroy the charging function of the Timeport. All LiPo cells sold by Heron Circuits are polarized correctly for Timeport.

Jack J4 provides regulated 5.0 volts at up to 2.0 amps on the pin marked VR. It allows access to all pins of the Proboard, and it accepts jumper wires from either the top or the bottom - because there are holes in the PCB located directly under each contact point. Jack J4 can also be connected to Sideboard projects that provide sensors, displays, or other components that can interact with a Proboard, or a Proboard PB.

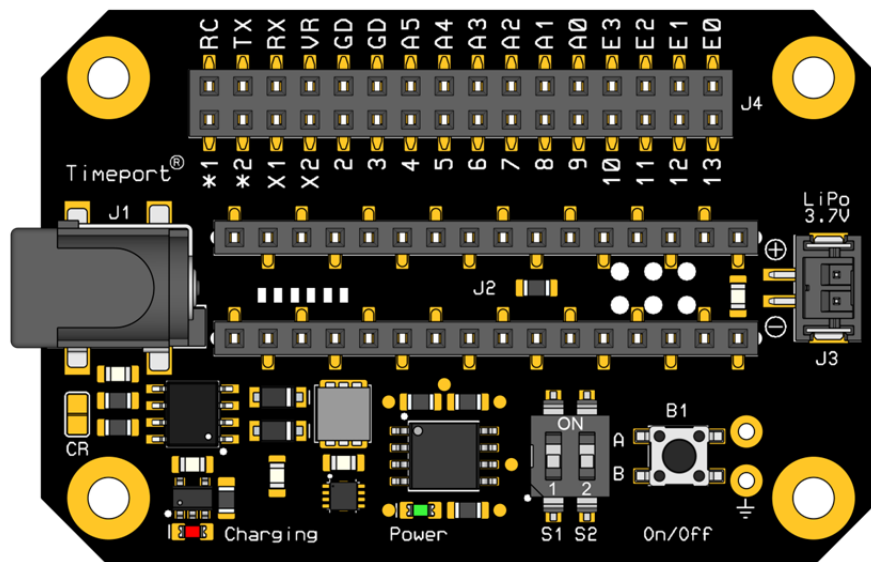
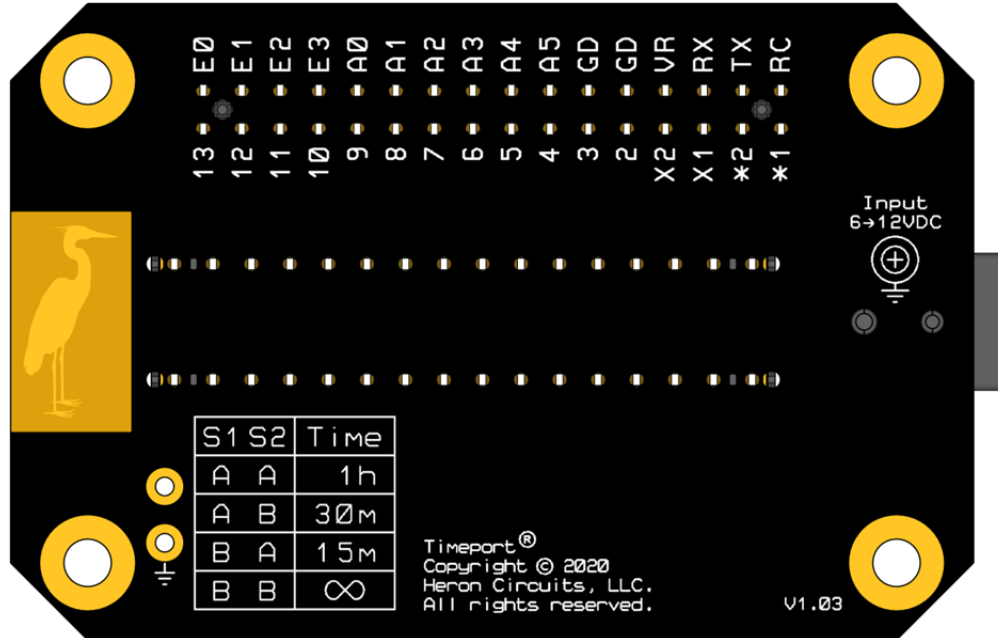

Figure 2 Top View

## 2. Timing Configuration



**Figure 3 Bottom View**

The bottom of a Timeport is smooth without any metal protrusions. It includes a printed table of settings for two switches, S1 and S2. The switches can be seen in Figure 2, and the table is shown in Figure 3. The switches S1 and S2 can be used for selecting a power shutdown timing interval. The infinite ( $\infty$ ) setting with each switch in the “B” position means Timeport will stay on without performing any automatic shutdown function. Users can select three other timeout intervals by using the switches, as shown in the table.

If the preset time values are not suitable for a user’s specific application, it is possible for a Proboard or a Proboard PB to send commands to a Timeport which will override the mechanical switches. See the description of commands in Section 5.

Button B1 is visible in Figure 2. It toggles the power state of the Timeport. If it is on, a press of B1 powers off the Proboard and any connected equipment powered by the regulated +5.0 volts DC on the VR pin of J4. If a Timeport is powered off, pressing B1 reactivates power and restarts the shutdown timer.

Two solder points are located near the B1 pushbutton, which is a normally open switch that shunts to ground when closed. The two solder points allow for connecting a separate pushbutton in parallel with B1. This is useful in cases where a Timeport is installed in a portable enclosure. Wires leading to an extra panel-mounted pushbutton should be as short as possible.

### 3. Charging Functions

The battery charging function of a Timeport allows seamless switching from external power to using a battery. It works like charging the battery of a smartphone. Connect an external power source, and the system runs on external power. If the external power fails or is disconnected the battery takes over without interrupting power to the Proboard.

When external power is available, Timeport monitors the LiPo cell. If the cell needs to be charged, a smart charging profile starts automatically. The red LED illuminates next to the word “Charging.” The charging indicator stops glowing after the cell is full, and is no longer charging.

By default, the charge function will pump up a flat battery at a rate of 100 mA. The rate will taper to zero at the end of a full recharge cycle. A solder jumper marked “CR” controls the charging rate. The CR gold pads can be seen near the lower left corner of Figure 2. If using a LiPo cell with a capacity greater than 0.750 Ah, the CR pads can be jumped with a small blob of solder to increase the charge rate from 100 mA to 350 mA. We recommend always scrubbing the soldered connection with isopropyl alcohol and a PCB cleaning brush in order to remove any flux and prevent chemical corrosion of metal surfaces.

### 4. Important Notes on Safety

Using the greater 350 mA charging rate with a low capacity LiPo cell (< 0.750 Ah) could result in overheating of the cell, and could ultimately result in damage which is not covered under warranty. The user assumes all risks associated with installing and operating LiPo cells. Heron Circuits will not be liable for losses or injuries resulting from using batteries.

The simplest way to improve safety is a combination of factors. Use unmodified equipment with all wiring polarities connected as recommended. Use small batteries and low charging rates, where possible. If modifying the equipment, you assume all responsibility, so seek the guidance of an experienced electronics Guru to double check everything before operating the equipment.

Note that if you modify the equipment to use the greater 350 mA charging rate, the charging control chips will become hot. This is a normal behavior when very small chips manage high currents. Chips on the Timeport contain thermal monitoring and current limiting functions that protect the chips from damage due to heat, but it is up to the user to avoid putting fingers or other materials in contact with the chips while running hot. If you find yourself with the reverse image of a chip burned into your fingertip, consider it a lesson learned. You can check to see that a chip is hot without touching the chip.

## 5. Schematic

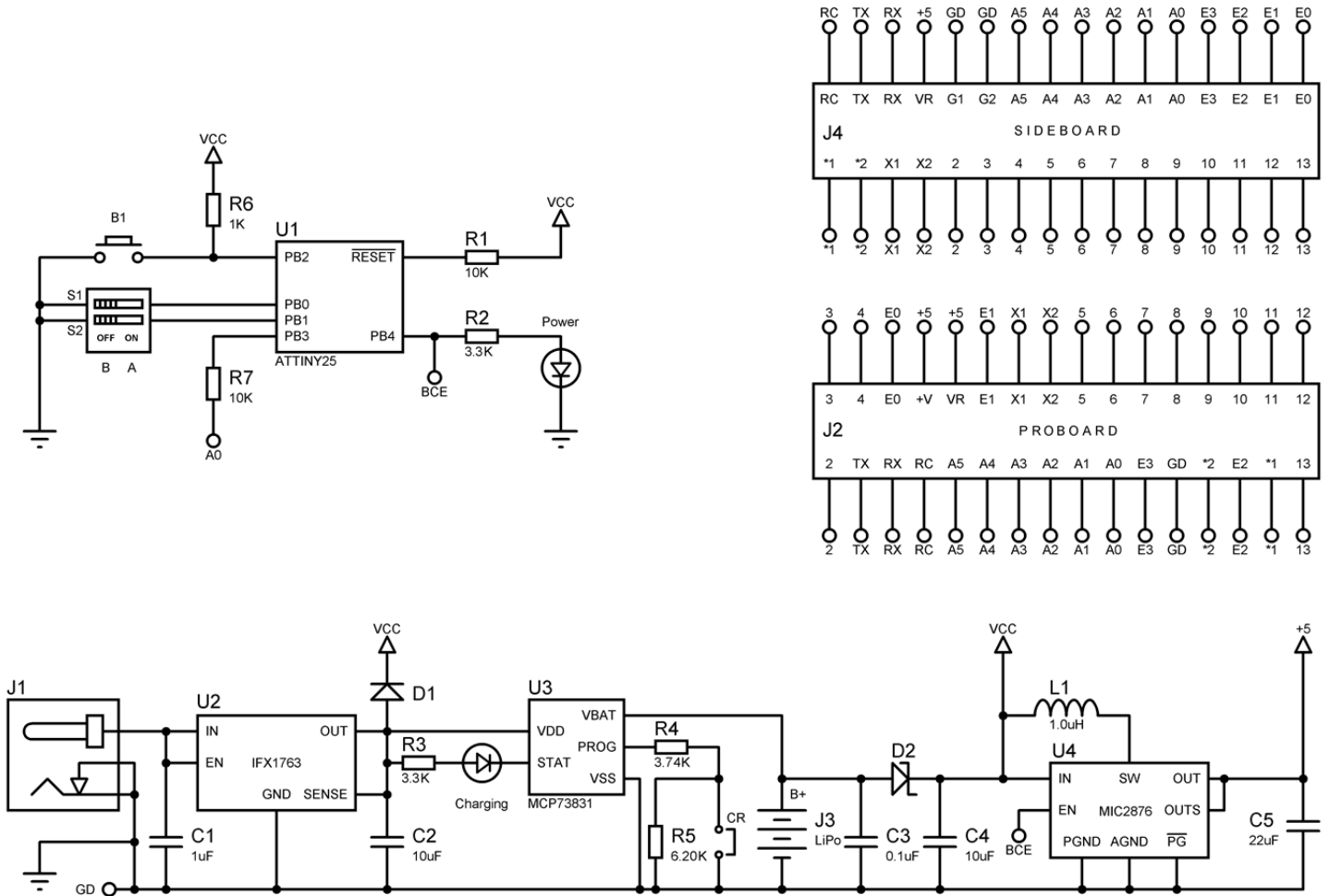

**Figure 4 Schematic**

In Figure 4, the chip U1 is an ATtiny25 microcontroller. U1 decides when to send a Boost Converter Enable (BCE) signal to the U4 voltage boost converter chip. The ATtiny25 sets the status of BCE based on monitoring the status of button B1, switches S1 and S2, and the patterns of signals on the Proboard's A0 pin which is connected to pin PB3 of U1. The ATtiny25's input pin, PB3 remains in a high impedance state, so the A0 pin of the Proboard is not loaded. Any time U1 decides to disable the boost converter, it also powers itself off. In the off state, it waits for a user to press the B1 button again to initiate a power on interrupt.

The arrangement allows conveniently controlling the timing of power for a Proboard 328P, or a Proboard PB by setting configuration switches S1 and S2, or by sending signals to the Timeport.

## 6. Commands from the Proboard

A Proboard can send commands using its A0 output pin to control a Timeport. Commands are sequences of square wave pulses at 10 Hz, of either polarity, with periods of no activity immediately before and after the sequence. Pulses can be positive with a zero baseline or inverted. Either way works, but a valid sequence must have pulses of the same polarity throughout.

The structure of the required pulses combined with the extra low frequency results in a simple but effective command language. The patterns are unlikely to appear on the Proboard's A0 pin as a result of random actions, but will be recognized when a user specifically directs a Proboard to send a power command to the Timeport. At other times Timeport will passively monitor the A0 pin.

**Table 1 Timeport Commands**

Pulses	Toggles	Name	Command Description
3	6	Off	Shut down immediately.
4	8	On	Set timeout to infinity.
5	10	15	Set timeout to 15 minutes.
6	12	30	Set timeout to 30 minutes.
7	14	60	Set timeout to 60 minutes.
8	16	Resume	Resume using mechanical switches to control timeout.

In an application where a timeout interval should be different from any of the available preset values, a Proboard can internally determine when to shut down, and then send an "Off" command. This will terminate power to the Proboard and any other device(s) powered by Timeport until B1 is pressed again.

Each change of the timeout period causes the countdown to start at the beginning. For example, if a Timeport is 40 minutes into a 60 minute countdown, changing the timeout period to 30 minutes will not result in an immediate power off. Instead, it will result in starting a new 30 minute countdown. The following sketch shows how to send an immediate shutdown command:

```
void setup() {
  pinMode(A0, OUTPUT);
  _delay_ms(100); // Allow 100 ms of inactivity on A0 before the command.
  for (int i = 1; i <= 6; i++) { // Send a set of three pulses (six toggles).
    digitalWrite(A0, !digitalRead(A0)); // Toggle the output state of pin A0.
    _delay_ms(50);
  }
  _delay_ms(100); // Allow 100 ms of inactivity after any set of pulses.
}

void loop() {
}
```



## **7. Additional Resources**

Related Products:

[https://files.heroncircuits.com/documents/Proboard\\_328P\\_Datasheet.pdf](https://files.heroncircuits.com/documents/Proboard_328P_Datasheet.pdf)

[https://files.heroncircuits.com/documents/Proboard\\_PB\\_Datasheet.pdf](https://files.heroncircuits.com/documents/Proboard_PB_Datasheet.pdf)

[https://files.heroncircuits.com/documents/Proboard\\_21J\\_Datasheet.pdf](https://files.heroncircuits.com/documents/Proboard_21J_Datasheet.pdf)

[https://files.heroncircuits.com/documents/Polaron\\_Datasheet.pdf](https://files.heroncircuits.com/documents/Polaron_Datasheet.pdf)

## **8. Notice**

### **IMPORTANT NOTICE – PLEASE READ CAREFULLY**

Heron Circuits reserves the right to make changes, corrections, enhancements, modifications and improvements to Heron Circuits products and/or to this document at any time without notice. Purchasers should obtain the latest relevant information on Heron Circuits products before placing orders. Heron Circuits products are sold pursuant to Heron Circuits' terms and conditions of sale in place at the time of order acknowledgement.

Purchasers are solely responsible for the choice, selection, and use of Heron Circuits products and Heron Circuits assumes no liability for application assistance or the design of the Purchaser's products.

No license, express or implied, to any intellectual property rights is granted by Heron Circuits herein.

Resale of Heron Circuits products with provisions different from the information set forth herein shall void any warranty granted by Heron Circuits for such product.

Information in this document supersedes and replaces information previously supplied in any prior versions of this document.